



# WARRANTY

Vengeance Clutch by Competition Clutch, Inc. (CCI) ensures all warrant-able items to be free from defects in material and workmanship for 1 year from date of purchase from an authorized dealer. Vengeance Clutch's responsibility is limited to repairing, replacing or crediting a customer's account for other Vengeance Clutch products. Credit will never exceed the invoice total of original sale of product. Under no circumstances will Vengeance Clutch be liable for labor, transport and/or storage of vehicle nor shall Vengeance Clutch be liable for damages or injury to any person due to the misuse or improper installation of its products subject to this warranty.

**Vengeance Clutch by Competition Clutch deals only through their authorized chain of distribution for all warranties and returns. Please contact the authorized dealer you purchased the product from before contacting Vengeance Clutch directly with proof of purchase.**

If new parts are required by the customer before original parts are returned to Vengeance Clutch, the customer is responsible for purchasing the new parts.

Vengeance Clutch by Competition Clutch reserves the right to inspect any and all parts returned for warranty to determine the reason for failure. In order to obtain warranty consideration, the entire clutch assembly including the pressure plate, the clutch disc, the release bearing, the pilot bearing/bushing (if applicable), along with proof of flywheel resurfacing or flywheel replacement must be returned for inspection. All parts and supporting documents must be returned to Vengeance Clutch before any consideration for warranty may be given.

All product returns require a Return Goods Authorization (**RGA**) number which will be issued by directly contacting Vengeance Clutch at **support@vengeanceclutch.com** with the following information:

- Proof of purchase with date (**no return will be accepted without this document**)
- Proof of flywheel resurfacing or replacement
- RGA Submission Form (CCI will send the form directly once RGA is approved)

Merchandise returned for inspection or repair must be sent by prepaid freight, insured and properly packaged. The RGA form must be supplied inside of the package. Freight charges (inbound) for returned products are the sole responsibility of the customer.

**There are no other warranties, expressed or implied, other than what is set forth here.**



**California Proposition 65 WARNING:**

This product may contain chemicals known to the state of California to cause cancer or birth defects or other reproductive harm.

## DM2-07-04 Fitting and Installation Instructions

# INSTALL INSTRUCTIONS

### Before Install:

Failure to observe and follow these instructions when installing the new clutch will void all warranties.

1. Confirm that all parts are included in the package. (Email Vengeance at support@vengeanceclutch.com for any questions or concerns)
2. Review instructions included with your packaging. Do not throw away instructions. Instructions should be used by installer and saved for future reference.

Part Number	Description	QTY
98140	Pressure Plate	1 ea
AT0023	Alignment Tool	1 ea
DRH240-845-S-B	Ceramic 23T Disc - Bottom	1 ea
DRH240-845-S-T	Ceramic 23T Disc - Top	1 ea
LT-243-CAP	Loctite Capsule - Blue	1 ea
LT-262-CAP	Loctite Capsule - Red	1 ea
M10-1X19DHHB12.9	Flywheel Hardware - 70 Lb Ft	8 ea
M8-1.25X20SHCS12.9	Pressure Plate Hardware - 26 Lb Ft	6 ea
TM1-7199-M2	Flywheel	1 ea
TM4-PP-WASH	Pressure Plate Hardware	6 ea
TM7-MID-240	Mid Plate	1 ea

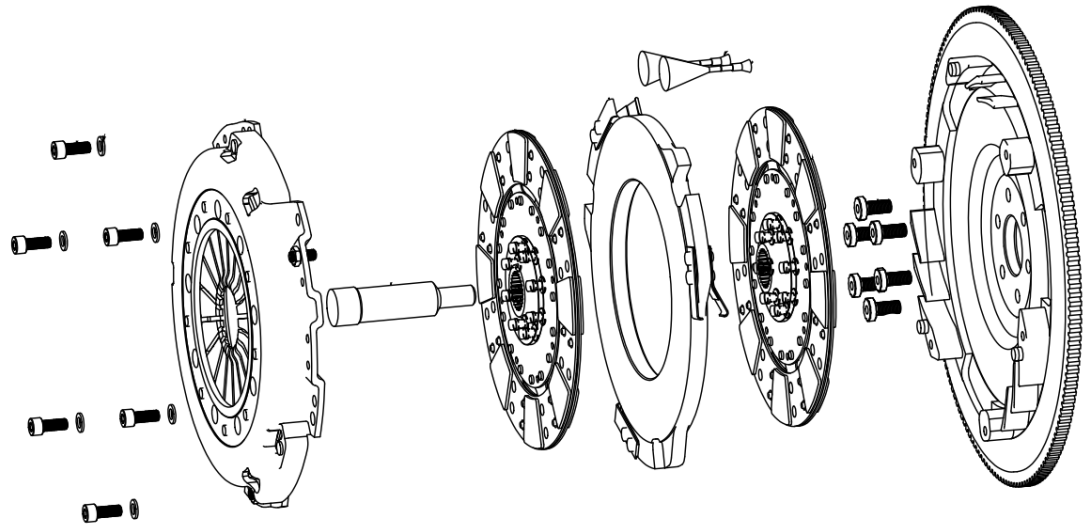

1. Ensure all components are included within the new clutch assembly. If you have any questions, please contact us at 800-809-6598 or support@vengeanceclutch.com
2. While removing the prior clutch assembly, inspect all components for any damage or foreign wear. This will assist in preventing any potential issues with the new assembly.
3. Verify the release system components are not worn or damaged. If you have any questions, please contact us at 800-809-6598 or support@vengeanceclutch.com
4. Clean the gear box main drive shaft splines, checking that the new clutch discs slide freely on the input shaft. Grease the input shaft lightly with high melting point grease. Lack of lubrication will cause improper release and clutch drag. Too much grease may cause slipping issues and premature failure of the assembly.
5. Lightly grease the outside diameter of the bearing guide tube for smooth sliding of the bearing collar. Ensure the release bearing is fully fitted to the clutch fork. Move the fork forwards and backwards to confirm the bearing is secure before refitting the gear box.

\*Photo representation may differ than the product being installed.

### Step 1:

Locate your **8** crank bolts and apply a small amount of **RED** Loctite to the threads.

Part Number: **M10-1X19DHHB12.9**



### Step 2:

Bolt the flywheel to the crank using the diagonal cross pattern. Never use air tools to install a flywheel.

- Run bolts down by hand.
- Torque bolts to **35 Lb Ft.** in crisscross pattern to ensure congruent tightening.
- Repeat previous process by torquing the bolts in a crisscross pattern to total **70 Lb Ft.**
- Wipe the flywheel with brake clean and towel to remove any potential residue on the flywheel contact surface at this time.
- **Never use air tools to install a flywheel.**



### Step 3:

Ensure the proper disc orientation. The clutch assembly provided will have orientation marks on the side profile for proper lining of both discs, the mid plate, and flywheel. The discs will also notate their placement and orientation.

- Install the bottom disc/first disc labeled "Trans Side of Disc."
- Next, install the mid-plate.



# VENGEANCE

CLUTCH

# INSTALL INSTRUCTIONS

## Step 4:

Ensure the proper disc orientation. The clutch assembly provided will have orientation marks on the side profile for proper lining of both discs, the mid plate, and flywheel. The discs will also notate their placement and orientation.

- Following the mid-plate installation, install the top disc with the etched "trans side of disc" facing towards the transmission.



## Step 5:

Insert the alignment tool into the center of both discs. Ensure both are aligned.



## Step 6:

Install the pressure plate onto the flywheel dowel pins:

- Align with the orientation markings provided by Vengeance Clutch
- Do not contact the alignment tool during fitting.
- Verify discs are centered and not "pinched" in any fashion.



## Step 7:

Gather the **6 Pressure Plate Bolts** and **6 Pressure Plate Washers**

- **M8-1.25X20SHCS12.9**
- **TM4-PP-WASH**



## Step 8:

Bolt the Pressure Plate Bolts and Washers:

- Ensure "star pattern" is utilized for congruent tightening.
- Torque to **26 Lb Ft.**
- If uneven pressure plate diaphragm fingers occur, remove hardware and start over.
- **Never use air tools to install a clutch cover assembly.**

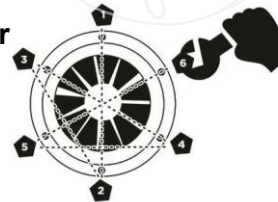

**9.** Refit the gear box. Never allow the gearbox to hang by its input shaft, as this will cause damage to the clutch assembly. Take care to not bend the disc.

**10.** Check all bell housing dowels to be sure they are in the correct position and tighten bell housing bolts. Make sure there is no debris or material between the mating surfaces of the engine and bell housing.

**11.** Perform required clutch adjustments to vehicle's manufacturer's specs and reset the clutch master cylinder push rod to obtain the proper pedal release position. Keep in mind, the pressure plate diaphragm position has changed with this installation.

**12.** Always check the clutch cable if you are unable to release the new clutch. Start by replacing the cable. If it is hydraulic, start by checking the clutch master cylinder and slave, ensuring there is no air in the system. This is essential to obtain maximum travel for release.

**13.** Road test vehicle. Never abuse a newly fitted clutch. Performing a 500-700 mile break-in is necessary to ensure the proper operation of your clutch. If applicable, a pedal adjustment is required following installation, at 700 miles, and again at 1000 miles. Adjust thereafter every 10,000 miles.



# INSTALL INSTRUCTIONS

## Proper grease application for your clutch disc

\*Warranties are void for any returns matching the left example



Example of TOO MUCH GREASE. Excessive application of grease will cause the excess amount to "spray" onto your friction surfaces during operation. This will saturate and prematurely fail your disc material.

Example of a perfect application amount. This is just enough for smooth installation, and barely visible to the naked eye.

