

advanced FLOW engineering

Cold Air Intake System

Instruction Manual P/N: 54-13064R / 54-13064D

Make: FORD

Model: F-150

Year: 2021-2022

Engine: V8-5.0L



- Please read the entire instruction manual before proceeding.
- Ensure all components listed are present.
- If you are missing any of the components, call customer support at 951-493-7185.
- Ensure you have all necessary tools before proceeding.
- Do not attempt to work on your vehicle when the engine is hot.
- Retain factory parts for future use.

| Label | Qty. | Description | Part Number |
|-------|------|---|--------------|
| A1 | 1 | Air Filter (Pro 5R) For 54-13064R | 24-91149 |
| A2 | 1 | Air Filter (Pro DRY S) For 54-13064D | 21-91149 |
| B | 1 | Tube, Rotomold | 05-5413064B1 |
| C | 1 | Housing, Rotomold | 05-5413061B2 |
| D | 1 | Coupling, Elbow Reducer | 05-01587 |
| E | 1 | Clamp, 060 (3-5/16" – 4-1/4") | 05-50002 |
| F | 1 | Clamp, 072 (3" – 5") | 03-50010 |
| G | 2 | Retainer Clip, Christmas Tree Style | 03-50616 |
| H | 1 | Seal, Trim: 13/32" Double Bulb 41.5" Length | 05-01534 |
| I | 1 | Inlet, Silicone | 05-01543 |
| J | 1 | Fitting, SAE 15.82 (5/8") to 3/8" NPT | 05-01339 |

Installation will require the following tools:

7mm, 8mm, 11mm and 13mm Nut Drivers or Ratchet and Sockets, Flat Head Screwdriver, 20mm wrench or adjustable wrench

Warranty Information available at: <https://afepower.com/contact#warranty>

Emissions Disclaimer: This product is not currently CARB exempt and is not available for purchase in California or for use on any vehicle registered with the California Department of Motor Vehicles.

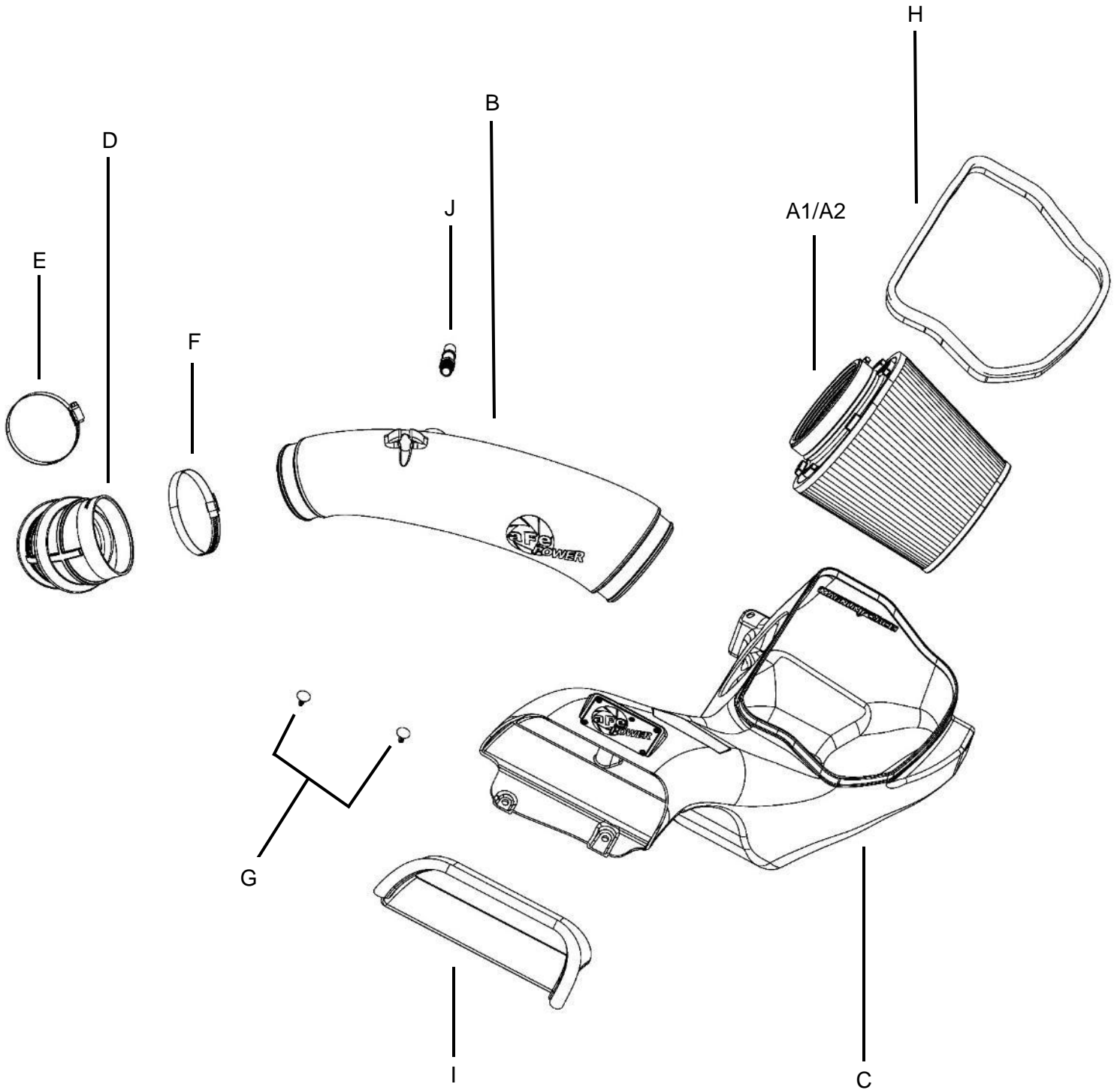



Refer to Figure A for Steps 1-3

Step 1: Loosen the clamp securing the intake tube to the throttle body.

Step 2: Detach the coolant hose from the intake tube.

Step 3: Disconnect the vent hose connected to the intake tube. Push down on the black clip of the quick disconnect fitting then pull the connector out of the fitting.



Figure B

Refer to Figure B for Steps 4-6

Step 4: Unlatch the two clips securing the air box lid.

Step 5: Remove the air box lid and intake tube from the vehicle.

Step 6: Remove the factory air filter from the air box.

**Figure C****Refer to Figure C for Steps 7-8**

Step 7: Remove the two plastic rivets securing the front scoop of the housing.

Step 8: Remove the screw securing the air box to the fender, then pull the factory air box out of the truck.

The screw will be reused to secure the aFe POWER housing.

**Figure D****Refer to Figure D for Steps 9-11**

Step 9: Install the seal trim onto the top edge of the aFe POWER housing.

Step 10: Install the inlet seal piece onto the inlet of the scoop of the housing.

Step 11: Transfer the factory grommet and sleeve from the factory air box to the aFe POWER housing.



Figure E

Refer to Figure E for Steps 12-14

Step 12: Install the aFe POWER housing into the truck by pushing it into the factory mounting grommets.

Step 13: Secure it using the factory screw removed at step 8.

Step 14: Secure the front of the housing with the two provided plastic retainer clips.



Figure F

Refer to Figure F for Step 15

Step 15: Remove the filter clamp from the aFe POWER air filter. Slide the air filter into the aFe POWER housing from the top opening. Then guide the filter flange through the round opening in the housing and snap in the filter. Orient the filter to have the longer dimension of the flange horizontal. Place the filter clamp over the filter flange but do not tighten at this time.

**Figure G****Refer to Figure G for Step 16**

Step 16: Install the NPT fitting onto the aFe POWER tube. This is a NPT connection, do not overtighten it.

The small space between the hex part and the tube is normal.



Figure H

Refer to Figure H for Step 17

Step 17: Install the coupling and clamps onto the throttle body, but do not tighten clamps yet.

**Figure I****Refer to Figure I for Steps 18-19**

Step 18: Install the aFe POWER intake tube into the filter flange then install it into the coupling.

Step 19: Align the tube and filter, then tighten all clamps.

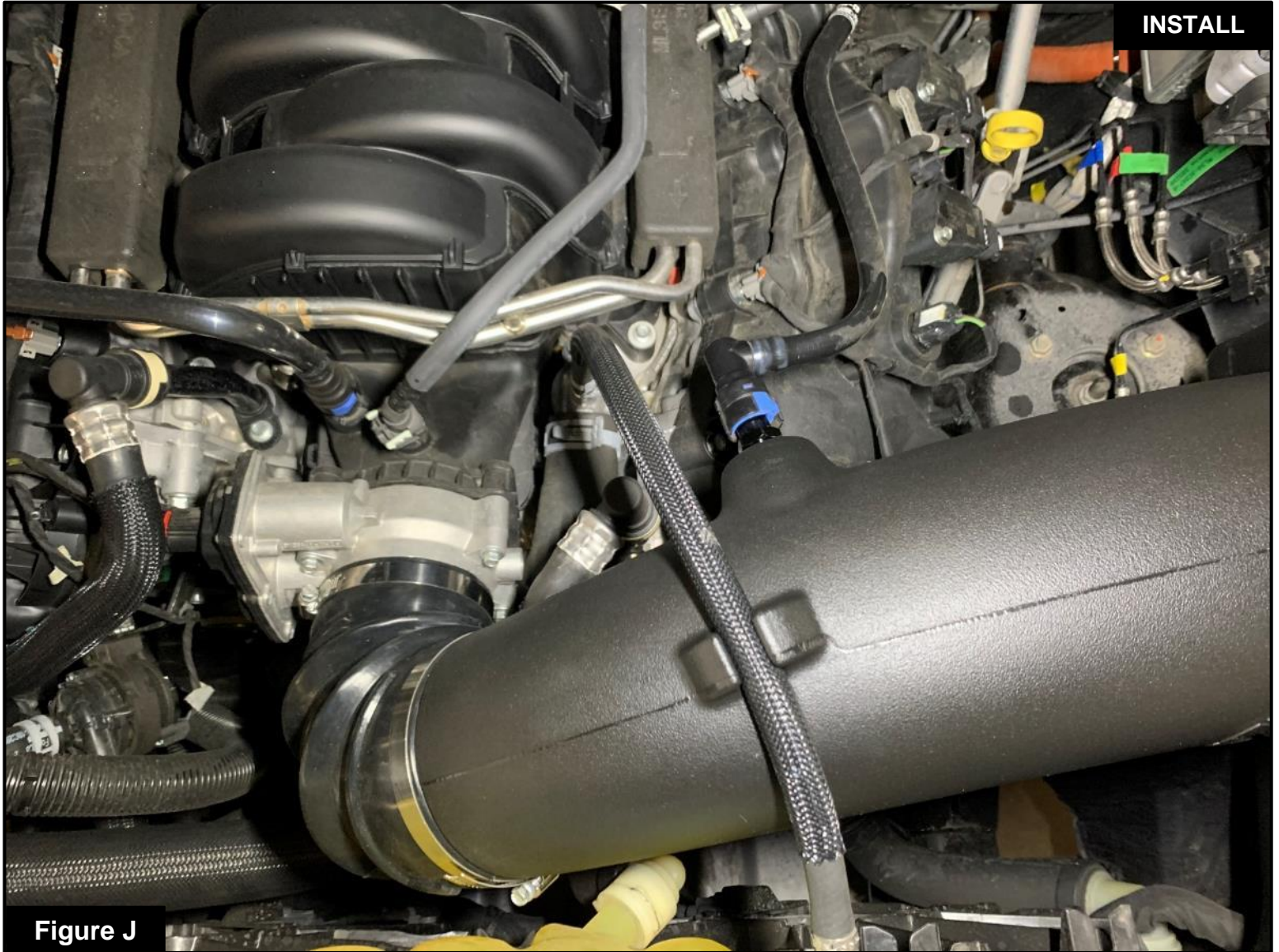

Figure J

Refer to Figure J for Step 20

Step 20: Connect the vent hose to the aFe POWER tube. Make sure the quick disconnect makes a snapping noise when fully engaged.

**Figure K****Refer to Figure K for Step 21**

Step 21: Verify all clamps and connections are secured. Your installation is now complete. Thank you for choosing aFe POWER!



PAGE LEFT BLANK INTENTIONALLY



advanced FLOW engineering, Inc.

252 Granite Street Corona, CA 92879

<https://afepower.com/contact>